



NAILI OIL FREE HV model Air compressor

USER MANNUAL

2021.7.01

Catalog

1	User notes	1
1.1	Operating instructions	1
1.2	Machine operating environment	1
1.3	Safety instruction	3
1.4	Statement	4
1.5	Machine identification	5
2	Product Introduction	5
2.1	Construction	5

2.2	Operating principle	6
2.3	Purpose and features	8
2.4	Product specifications and main technical parameters	8
3	Installation and use	9
3.1	Installation	10
3.2	Operation	12
4	Determination and maintenance	13
4.1	Inspection: safety valve	13
4.2	Maintenance:	15



5	Motor	17
6	Storage	17
7	Breakdown maintenance	20

1. User notes

1.1 Operating instructions

This manual can help users to operate and maintain the equipment correctly and safely. It is necessary to maintain and maintain the equipment according to the maintenance schedul, If the air compressor is working in a poor environment, service intervals should be appropriately shortened.

Repairs and adjustments should be carried out by professionals and must be made using spare parts provided by NAILI or its authorized agents

1.2 Machine operating environment

Air compressor should be installed in a well ventilated place, away from direct heat and prevent mud splashed on the machine, the environment temperature should be within the range - 40 ~ 65 °C

1.3 Safety instruction

1.3.1 Regulation

- The installation, start-up, operation and running of the air compressor shall be carried out in strict accordance with the safety operation rules;
- Installation, operation and maintenance shall be conducted by fully trained and qualified personnel of NAILI company;
- The owner of the air compressor shall fully maintain the air compressor, which is important for safe operation. All well-worn, wrong and damaged safety related parts shall be replaced immediately.

1.3.2 Transport and handling

When loading, unloading, lifting and transporting, the air compressor should be handled with care according to the direction of the arrow, It is strictly forbidden to tilt or invert to cause damage; Collision and impact should be avoided when moving and lifting the machine to keep its center of gravity stable; The equipment should be firmly fixed on all sides during transportation. When lifting the air compressor, care should be taken not to damage the load-bearing structure and the shell.

1.3.3 Identification markers

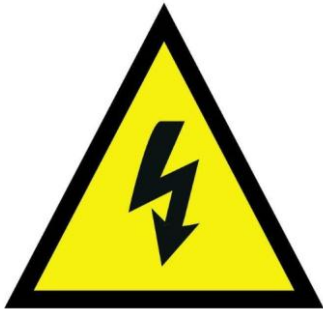
High temperature:	Danger High Voltage:
	

1.4 Statement

NAILI shall not be liable for personal injury and property loss caused by the following reasons

- ◆ Not comply with warning;
- ◆ Incorrect use of compressed air and air compressor;
- ◆ Not comply with normal safety instructions and work regulations;

- ◆ Lack of protection during loading, unloading and transportation;
- ◆ Equipment installation in wrong way;
- ◆ Incorrect connection of power cord and power supply, Incorrect connection of the pipe;
- ◆ Not implemented the normal maintenance;
- ◆ Unauthorized alteration;
- ◆ Not follow the operation instructions, the failure caused due to incorrect operation.

1.5 Machine identification

The nameplate of the machine can be easily found on the machine, for example:

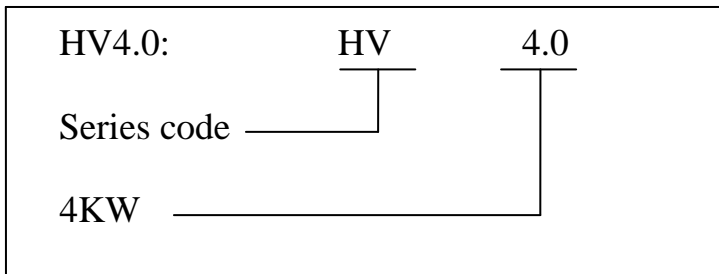

2. Product presentation

2.1 Structure

Oil - free piston air compressor is mainly composed of air compressor, base plate and other parts

2.2 Operating principle

2.2.1 Principle of compression

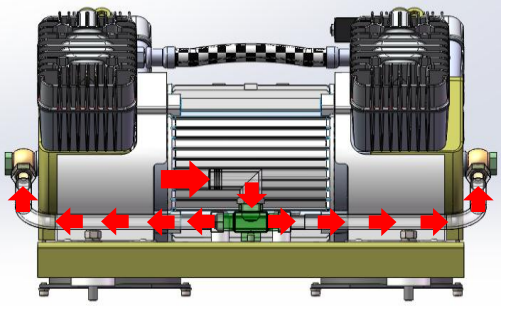
No	operating principle		Pic
1	Air inlet	Air is sucked through the air filter, and then enter the air compressor through the intake hose.	

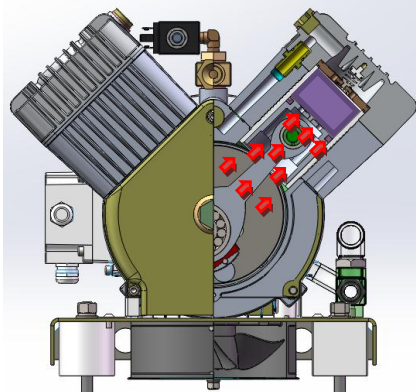
2	Compression	<p>When the piston body moves, the inlet valve opened, the exhaust valve closed, and the air enters the cylinder body. The air is compressed in the cylinder body</p>	
---	-------------	---	--

2.2.2 Cooling

The air compressor is cooled by an external axial flow fan, and the cooling effect is optimized by an independent cooling system

2.2.3 Main components of intake system

The air compressor intake system adopts high quality air filter with high filtering accuracy,

which role is to filter the dust and other impurities. Users should carry out regular maintenance or replacement according to the working conditions. Dust accumulation on the outside of the filter element can be gently blown away by low-pressure air from the inside out. If the filter element is seriously blocked or damaged, it should be replaced in time.

2.3 Uses and features

Oil-free piston machine is developed by NAILI as a new international leading level of oil-free piston air compressor., NAILI is a professional manufacturer which specializes in design, production of air compressor. With advanced technology and strong technical strength to produce high reliability, high economy, high quality air compressor. The product has the advantages of compact structure, light weight, stable and reliable operation, low noise and convenient installation. It's a new generation of safe, environmental protection, energy-saving air compressor

2.4 Product specifications and main technical parameters

name model	F.A.D (m ³ /min)	Pressure (Mpa)	Motor power (kW)	Air outlet size	Weight (kg) Without base
HV1.5	0.15	1.0	1.5	M22×1.5	32
HV2.2	0.22	1.0	2.2	M22×1.5	48
HV3.0	0.32	1.0	3.0	M22×1.5	48
HV4.0	0.38	1.0	4.0	M22×1.5	54

3. Installation

Special note: before you install and use this product, please read this manual in detail and follow the following safety operation requirements

3.1 Installation

The appearance and installation dimensions of the oil-free piston air compressor are shown in the figure.

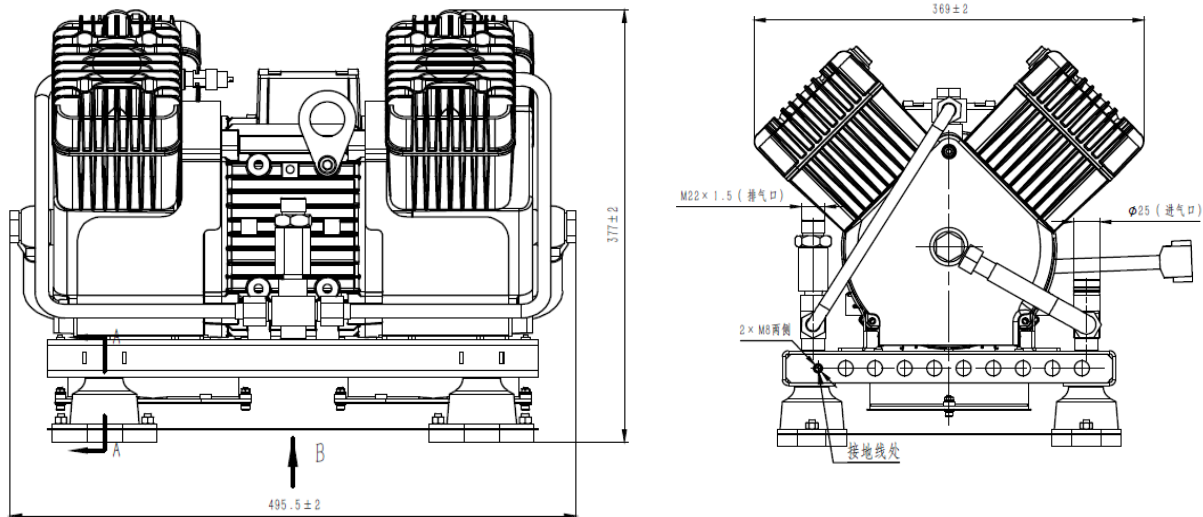

Note: this section is recommended according to installation size, our company can customize

the installation form and size according to user requirements

3.1.1 The installation of electrical elements must be carried out by a qualified electrician.

Standard electrical connection:

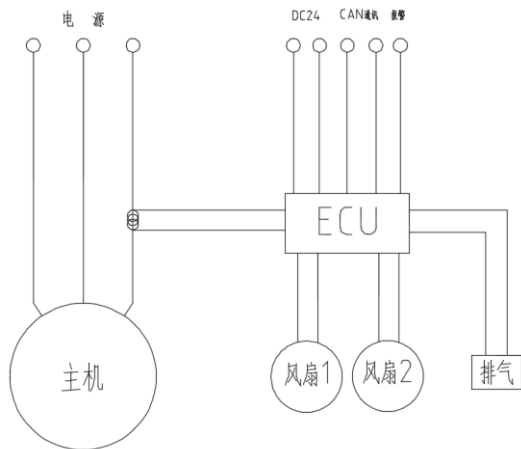

3.1.2 Air compressor must be well connected with Earth to ensure its safe operation.

3.1.3 The air pipe must be connected by a professional staff. The size of the pipeline conforms to the air compressor exhaust volume and exhaust pressure, Exhaust pipe should below the height of the airout port as far as possible, to facilitate the discharge of condensed water, in case of the water freeze the pipe. And it should be easily replaced, it is recommended to connect the hosepipe in the airout port, to prevent the hard connection damage caused by vibration. It is recommended to wrap the exhaust pipe with thermal insulation material or add heating and insulation devices for vehicles which are sold to cold areas.

3.1.4 Air compressor must be installed horizontally and firmly connected. It should be left with more than 100mm space in each sides for maintenance and maintenance. The air compressor installation space should in good ventilation condition; The cooling fan must be well protected where is under the air compressor.



3.1.5 There is strictly prohibited to pull and handle into/out of the air pipe of Air compressor in carrying in the process of installation, which will lead to deformation or fracture of the inlet/out pipe and affect the performance of the machine.

3.2 Operation

3.2.1 Check the unit before starting and remove foreign matters to ensure there is no interference.

3.2.2 Make sure electrical and piping connections are correct before starting.

3.2.3 Check whether there is air leakage in the connection of pipeline after starting. If there is, it should be removed immediately after the shutdown and pressure relief. When the air

compressor is running or there is pressure inside the equipment, do not remove parts of the machine to avoid injury.

3.2.4 The working pressure of the air compressor shall not exceed the rated pressure specified by the nameplate.

3.2.5 In case of any abnormality during operation, the machine should be stopped immediately and the power supply should be cut off. Inspection and maintenance shall be carried out by trained or maintenance personnel of the company.

4. Maintenance

4.1 safety valve

The safety valve has been set according to the pressure of the machine. Do not change or replace it.

4.2 Maintenance and servicing:

4.2.1 Maintenance Periodic Table

No	Item	Content maintenance	Part No.	quantity (pic/set)	Daily	Common	Optional
					1 week/once or 2000 km/once	1year/once or 60000 km/once	3years/once or 150000 km/once
1	Replace/ clean Air filter core	Individual	357020000001	2	○	●	●
		Integrated	357020000001	1	○	●	●
2	Fan	Abnormal sound	358050000038	2	○	○	○
		Clean					
3	Piston O-ring	Check and Replace/3KW	352020090005	4	-	-	●
		Check and Replace /4KW	352020090004	4	-	-	●
4	Piston Pin	Check and Replace /3KW	302010150005	4	-	-	●
		Check and Replace /4KW	302010150006	4	-	-	●
5	Shaft Seals	Check and Replace	352010040017	8	-	-	●

6	O-ring	Check and Replace /3KW	352010010218	4	-	-	●
		Check and Replace /4KW	352010010255	4	-	-	●
7	Damper	Checking	363070000030	4	-	-	○
8	Wires	Loosen	-	-	○	○	○
		Sealing	-	-	○	○	○
9	Cylinders	Checking	302010050007	4	-	-	○
10	Intake Air pipe	Checking Air leakage	-	-	○	○	○
11	Air tube	Checking leakage at joint	-	-	○	○	○
12	Check valve	-	361020000003	1	-	-	●

Attention: ○: Check/clean up. Replace if any abnormality is found during inspection;

●: replacement;

- : No need to deal with.

Note: mileage and time in the above maintenance cycle is subject to who is coming first, checking the sealing parts in maintenance. If there is any abnormality, please contact the professional for maintenance

Before cleaning the air filter core and air filter shell, the hose at the outlet of the air filter must be removed, Prevent dust from falling into the hose and inhaling air compressor due to careless operation. Remove the air filter core from the air filter assembly。 When cleaning the air filter core, please use about 4bar of dry and clean compressed air to blow from inside out. It is strictly prohibited to use water, gasoline cleaner and other liquids for cleaning. If the air filter core is too dirty, please replace it in time. When cleaning the air filter shell, use about 0.4mpa dry and clean compressed air to clean the dust on the surface and inside of the shell .

5.Motor

If air compressor is not used for long time or in a particularly humid environment, Insulation resistance of windings should be checked, Resistance value can not less than 20 m Ω .

The motor and the entire air compressor must be connected with earth.

6. Storage

Air compressor shall be protected against corrosion and damage during transportation and short term storage (3 months), If for long-term storage, please contact us

If it is damp climate, electrical and mechanical components should be stored in a dry environment.

7. Breakdown maintenance

breakdown	reasons	solution
air compressor is difficult to start	Missing phase or incorrect wiring	Electrical personnel maintenance
	Electrical, wiring, or motor malfunction	Check fuse, switch, terminal post, motor one by one
	The inside pressure of the air storage tank is between the automatic stop pressure and the starting pressure (Air compressor does not need to start)	Release the pressure of the gas storage tank
	Solenoid valve damage	replace Solenoid valve

The motor overheats or even burns out	The voltage is too low or too high	Check reason
	Electrical connection column is loose	Check and exclude
	Exhaust pressure exceeds the maximum allowable pressure, resulting in motor overload	Reduce the pressure, so that the machine in the normal pressure range of use (If necessary, contact the vehicle factory after-sales)
	Ambient temperature is too high	maintain ventilation
abnormal noise	loose joint	Tighten joint points
	Motor bearing, connecting rod bearing lack of oil or damage	Repair, grease or replace (Contact our after-sales staff)
Fan not running	Fan damage or checking setting of ECU	Check and replace
The pressure of the air tank is insufficient or the charging time becomes longer	Air leakage in pipe or joint	Check and replace
	Suction filter blockage	Clean or replace the filter core
	Suction and exhaust valve disc damage or piston ring and cylinder wear	Check and replace
	Low voltage results in slow motor speed	Check and replace
	Dry air does not exhaust	Check and contact vehicle factory for after-sales treatment

motor damage	Under the control of variable frequency power supply, the frequency converter does not match the motor	Choose a frequency converter that matches the motor
	Has not debugging as required by frequency converter	Debug as required
	Air compressor internal stuck	Contact NAILI
	Apparatus failure	Maintenance and elimination by electrical personnel

Note: the owner of the air compressor is responsible for the maintenance of the air compressor. All worn, defective and damaged parts must be replaced immediately. Inspection operations and maintenance shall be carried out by competent trained personnel.

The power supply must be cut off before troubleshooting, and the pressure inside the machine can be cleaned side by side before proceeding. If the user is not competent for fault analysis and troubleshooting, Please contact us.